

DP3114-BTRY

DOLPHIN PRESTIGE TOUCH FREE PAPER TOWEL DISPENSER

MANUAL



January 2024

D
DOLPHIN

CONTENTS

**VERY IMPORTANT. SAVE THESE INSTRUCTIONS FOR FUTURE REFERENCE.
READ AND KEEP IN MIND ALL INSTRUCTIONS AND RECOMMENDATIONS
DESCRIBED THROUGHOUT THIS MANUAL.**

3	Liability and warranty
4-6	General safety instructions
7-11	Product description
12-15	Mounting
16-19	First use
20	Assistance with faults
21-22	Maintenance
23	Detergents
24	Disposal

LIABILITY AND WARRANTY

Any liability and warranty of the manufacturer is excluded if

- › The product is not used as intended
- › The notices and instructions in the instructions for use are not observed
- › The product, including accessories, is used incorrectly
- › The product, including accessories, is not maintained or is improperly maintained
- › The product, including accessories, is improperly repaired and non-genuine spare parts are used
- › Modifications and functional changes are made without the manufacturer's consent.

Any liability and warranty of the manufacturer is expressly excluded if

- › The product is damaged due to inadequate fastening or exceeding the max. load of 15kg.

Warranty claims on the manufacturer are governed by the Terms and Conditions of Sale and Delivery of

Dolphin Solutions Ltd
Southpoint
Compass Park
Junction Rd
Bodiam
Robertsbridge
TN32 5BS

Subject to technical modifications!

Due to constant further development, illustrations, function steps and technical data may differ slightly.

GENERAL SAFETY INSTRUCTIONS



These instructions for use have been prepared specifically for personnel servicing the DP3114-BTRY paper roll dispenser. They contain important information for installing, operating and cleaning the system.

DUTY OF CARE OF THE USER

The touch free paper roll dispenser has been designed and constructed on the basis of a hazard analysis and careful selection of the harmonised standards to be observed, as well as other technical specifications. It therefore conforms to the latest technology and guarantees the highest possible degree of safety.

However, this degree of safety can be achieved in practice only if all the measures required for this purpose have been taken. The user of the product has a duty of care to plan these measures and to monitor the implementation thereof.

The user must ensure in particular that

- › The product is used only as intended (cf. also the product description section).
- › The product is used only in a faultless, fully functional condition.
- › The instructions for use are legible and complete at all times.
- › Only adequately qualified and authorised personnel maintain and repair the product.
- › These personnel are regularly instructed in all relevant issues concerning occupational safety and environmental protection, and also that these personnel understand the instructions for use and in particular the safety instructions contained therein.
- › All safety and warning notices attached to the product are not removed and remain legible.

GENERAL SAFETY INSTRUCTIONS

EXPLANATION OF THE SAFETY SYMBOLS USED



Caution!

Indicates a potentially hazardous situation which, if the safety regulations are not observed, can result in property damage, minor or moderate physical injury.



Warning!

Warning – Dangerous electrical voltage



Important!

For instructions for use and other useful information.

BASIC SAFETY MEASURES

It must be guaranteed that all persons who have to undertake activities on the product can view the instructions for use at all times. In addition to the instructions for use, operating instructions as defined in the Occupational Safety and Health Law and the Equipment Usage Directive shall be provided.

All safety notice signs and operating information signs on the product must be readily legible at all times. Signs that have become damaged or illegible must be replaced immediately.

The touch free paper roll dispensers are not designed for use by any persons (including children) with limited physical, sensory or mental aptitude or lack of experience and/or lack of knowledge, unless they are supervised by a person responsible for their safety or have received instruction from this person as to how the product is used.

Children should be supervised to ensure that they do not play with the product.

REQUIREMENTS FOR SERVICE PERSONNEL

The product may only be operated by persons who are trained, instructed and authorised to do so. These persons must understand these instructions for use and act accordingly. The respective authorities of the operating personnel must be clearly defined.

All persons who undertake activities on the product must read the instructions for use and sign to confirm that they have understood the instructions for use.

GENERAL SAFETY INSTRUCTIONS

SPECIAL HAZARD TYPES



Caution! Crushing hazard!

When relocating the product, it is important to ensure that no body parts are placed between the product and the vicinity or fixture.



Caution! Crushing hazard!

When closing the door, it is important to ensure that fingers are not placed between the door and the product carcass.

When loading a new roll of paper towels, it is important to ensure that fingers, clothing, etc. are not caught in the loading mechanism.



Warning!

Warning – Dangerous electrical voltage

The product may be used only when in a technically faultless condition.



Attention!

Mains-operated dispensers must be connected to a customer-provided disconnect device that guarantees disconnection of all phases through contact separation of at least 3 mm per phase. During repair work, the dispenser must be disconnected from the means voltage.

PRODUCT DESCRIPTION



The touch free paper roll dispenser is suitable for commercial and public use.

It is a dispenser that delivers paper towels having a defined length from a paper roll.

The touch free paper roll dispenser reduces operating costs compared to those for a single sheet dispenser, since only one towel having an adjustable length is delivered.

The towel feed is adjustable from 20 cm to 120 cm.

The operation inhibit time is adjustable from 1 s to 6 s.

A new towel cannot be requested during this inhibit time.

The sensor for requesting a paper towel is a non-contact type and adjusts automatically to its environment. The product is designed for paper rolls having an outside diameter of max. 180 mm, with a length of 210 mm and an inside diameter of 50 mm.

To simplify service, the dispenser has a "remaining roll" function, i.e. if the current paper roll has a diameter of only approx. 100 mm, it can be lowered, allowing a new roll to be loaded. After the remaining roll has been consumed, the new roll loads automatically.

The touch free paper roll dispenser is available in two versions: mains-powered (230 V) or battery-powered (6 V). The door is screwed to the housing using 2 sturdy stainless steel hinges. The door is secured by a lock. Furthermore, the touch free paper roll dispensers have a storage compartment for spare paper towel rolls.

PRODUCT DESCRIPTION

INTENDED USE

- › The touch free paper roll dispenser is used to unroll paper towel rolls.
- › The touch free paper roll dispenser may be used only when in a technically faultless condition. Have malfunctions corrected immediately. A faulty product must be taken out of service immediately.
- › Follow the correct procedure when unloading the paper towel roll (see detailed description).
- › Instruct the cleaning and operating personnel on use and in particular on the maintenance requirements.
- › The instructions for use must be followed when using the touch free paper roll dispenser for the first time.
- › Do not use cleaning materials which can lead to damage if used incorrectly. (see Cleaning section)
- › The touch free paper roll dispenser may be loaded only with suitable paper towel rolls (outside diameter of max. 180 mm, length of 210 mm, inside diameter of 50 mm).



Using the touch free paper roll dispenser contrary to the intended use will render the warranty invalid. Furthermore, the manufacturer shall not be held liable in this case.

In particular, we point out that

- › The product is not suitable for unrolling cloth hand towels or liquid-impregnated paper towel rolls.

PRODUCT DESCRIPTION

CONSTRUCTION OF THE TOUCH FREE PAPER ROLL DISPENSER

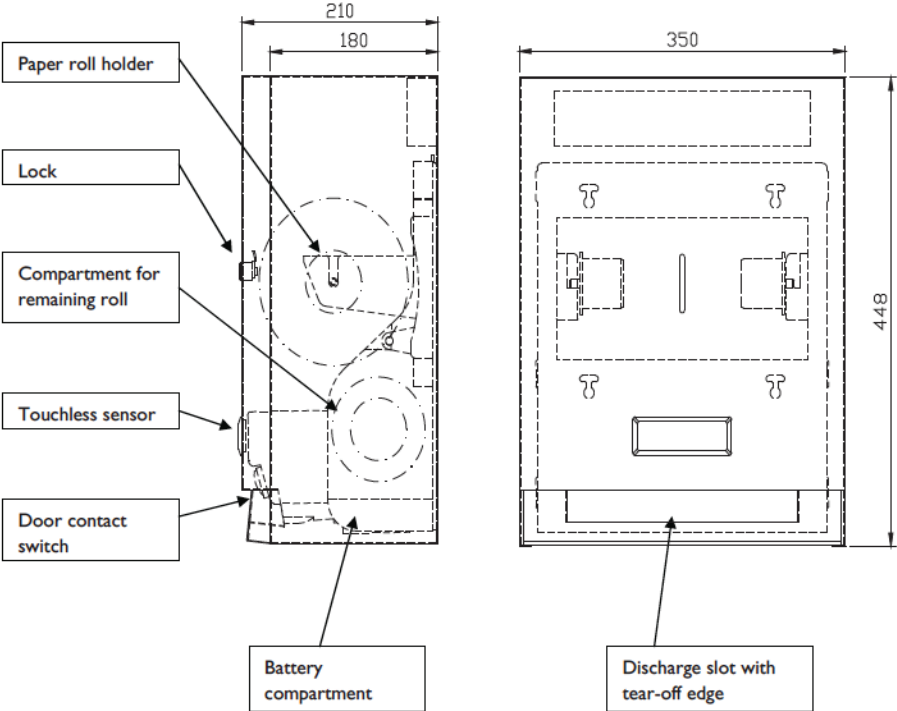

PRODUCT DESCRIPTION

TECHNICAL DATA

General	
Dimensions length x width x height	350 x 448 x 210 mm
Empty weight	9.3 kg
Electrical connection data	
Rated voltage	6V
Total connected load	7 watts
Power supply	4 x 1.5V mono cell battery
Environmental conditions	
Ambient temperature	+10°C to +45°C

PRODUCT DESCRIPTION

AS-DELIVERED CONDITION AND SCOPE OF DELIVERY

- As-delivered condition:**
- > Packed in a box
 - > With protective film for the CNS surface (outside)

- Scope of supply:**
- > Touch free paper roll dispenser
 - > Manual for the electronic paper roll dispenser
 - > Initial fill
 - > Mounting materials

TRANSPORT AND UNPACKING

What to do?	Who does it?
Unload, transport and unpack packed product, dispose of the packaging.	Transport specialist



- > Remove external packaging.
- > Lift the product out of the box.
- > Dispose of films, solid foam and box separately (observe local regulations).
- > Check consignment for completeness and integrity.

MOUNTING

MOUNTING THE DP3114-BTRY

Using the provided mounting materials (4 screws, 4 wall plugs), attach the dispenser to the sides of a wall recess. All 4 fastenings facilities must always be used. The dispenser is supplied fully assembled and ready for use. No assembly work is required on the dispenser.

Fastening points

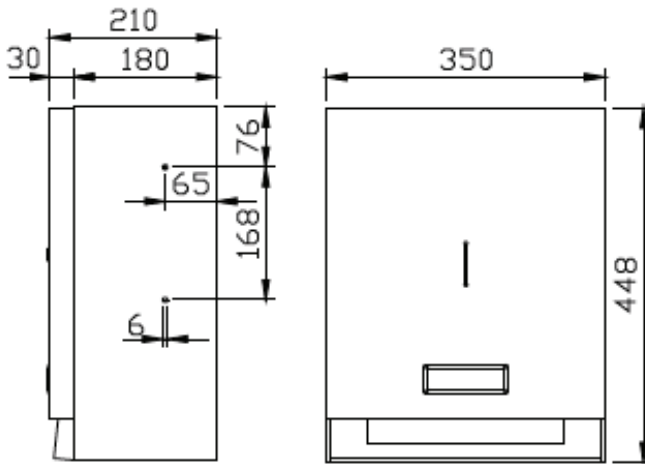

Wall recess:
min. 352 x 450 mm
Depth:
min: 100 mm
max: 180 mm

MOUNTING

PLACING THE PRODUCTS

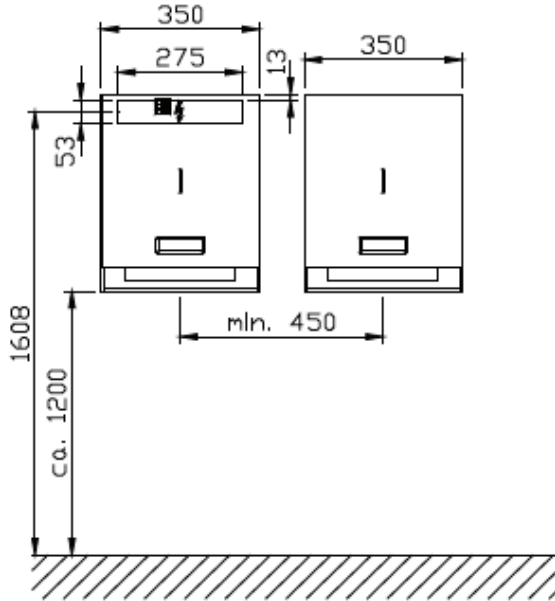

- › The lateral distance to the existing wall must be sufficiently large to allow the door to be opened and to prevent any risk of fingers, clothing, etc. becoming trapped.

MOUNTING SEQUENCE

- › Drill 4 mounting holes as per dimensional sketch and insert wall plugs provided.
- › Open the door and mount the roll-fed paper towel dispenser on the wall using the screws provided.
- › Connect the mains cable directly to the connection terminals provided in the product. For battery-powered products, place
- › 4 x 1.5V mono cell batteries in the battery compartment.
- › Lock the door by means of the lock.

MOUNTING

ELECTRICAL CONNECTION

MAINS-POWERED OPERATION

Have a qualified electrician make the electrical connection to the touch free paper roll towel dispenser in order to ensure about the product is connected in compliance with safety regulations.

In rooms with showers and bathtubs, the product may not be installed in the safety zone specified in VDE regulations (0.6 m from the shower cubicle or bathtub and 1.2 m from the shower heads). This roll-fed hand towel dispenser must be installed beyond the reach of individuals using a bathtub or shower.

Connect the mains cable directly to the connection terminals provided in the product.

Mains connection: 1N AC 230 V 50 Hz

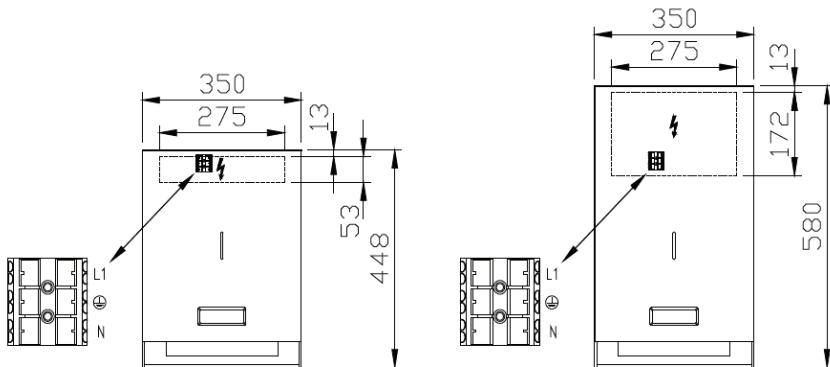

A disconnect device that guarantees disconnection of all phases through contact separation of at least 3 mm per phase must be provided at the installation site. The mains connection must be protected by a residual current protective device. The mains voltage and voltage data on the product identification plate must agree.

In rare cases of strong electromagnetic fields in the range of 440 kHz +/- 40 kHz, it is possible that the sensor might be actuated and initiates a single dispensing cycle. The dispenser should be ready to use again immediately once the disturbance no longer exists. To prevent erroneous actuation from occurring again, reduce the sensor range until the disturbance disappears.

BATTERY-POWERED OPERATION

The batteries can be placed in the dispenser or exchanged very easily by the end user. The dispenser is ready for use immediately after the batteries have been installed.

To do so, use the key to open the front door. Then remove the cover from the battery compartment in the bottom of the hand towel dispenser. Place the batteries in the compartment in accordance with the symbols on the bottom of the battery compartment and close the cover again.

Four (4) 1.5 V mono cell batteries are needed.

Please use only alkaline batteries (Type LR20).

FIRST USE

FIRST USE

The product is used for the first time by the operator.



Important!

Before first use:

- > Clean the touch free paper roll dispenser thoroughly (see cleaning chapter)
- > The electrical connection values at the installation site must match the data on the identification plate of the roll-fed hand towel dispenser.
- > Load a roll of paper

CHECKING THE FUNCTION

- > Correct insertion of the batteries or correct electrical connection can be checked by pressing the “Manual operation” button.
- > The motor and the paper transport mechanism continue to run as long as the “Manual operation” button is pressed.

MAKING THE BASIC SETTINGS

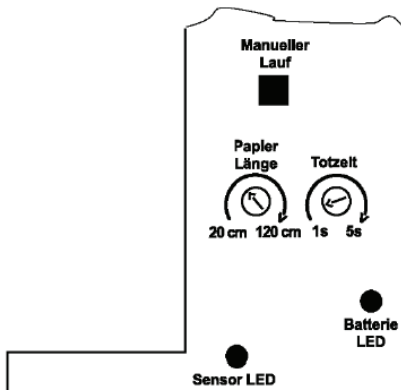

Factory settings on the touch free paper roll dispenser:

- > Paper feed: approx. 45 cm
- > Idle time: 1 s

The sensor LED glows green whenever a hand approaches the sensor.

The battery LED flashes red when the batteries need to be exchanged. (always replace complete set)

The motor is disconnected from the electricity whenever the door is open, thereby preventing unintentional operation of the dispenser.

The following settings are possible:

Paper length from approx. 20 cm to 120 cm. Depending on battery condition, the paper length may fluctuate slightly on battery-powered products.

Idle time from 1 s to 6 s, the operation inhibit time begins immediately after the dispensing cycle. Paper cannot be requested during this time. The set time is also indicated by the battery LED. The LED glows for the set idle time after paper has been dispensed.

FIRST USE

LOADING THE PAPER



To load the first roll, place the plastic holders into the left and right ends of the roll and then place the cylindrical stubs into the holders on the back wall of the dispenser



Using the blue lever on the left side, raise the paper guide at the front and guide the paper underneath it.



Paper is pulled in automatically and discharged by the dispenser upon pressing the "Manual operation" button. (The button is located under the removable spray guard and, if necessary, can be actuated by means of the product's key).



Tear off the first piece of paper, re-attach the spray guard, and close the dispenser door. The dispenser is now ready for use. It is possible to load a new roll even though the old roll as not yet been consumed completely.



To do so, remove the old roll from the upper holder and place it in the lower holder. Please press it down completely. The paper guide at the front is then raised automatically.



Using the 2nd pair of holders, load the new roll as described above. Direct the paper under the paper guide (see above) and press it against the two sharp points on the paper guide to secure it.

The dispenser is now ready for use, the door can be closed. The paper on the new roll is grasped and dispensed once the old roll is consumed almost completely.

OPERATION/SAFETY INSTRUCTIONS



Warning!

Risk of injury or property damage through improper use of the touch free paper roll dispenser



Caution!

Do not use running water or even high-pressure cleaners for cleaning!
(See cleaning section).
Clean the product only with a damp cloth.

Make sure that the product is not placed back in service unintentionally. If necessary, attach an appropriate warning sign (e.g.: "Out of service, do not connect to mains")



Warning!

Never clean electrical equipment with water or similar liquids.

ASSISTANCE WITH FAULTS

- › Repair work must only be carried out by service.
- › In case of faults, please contact the customer service department at Dolphin Solutions, stating the product type and the product number (see identification plate).
- › The address of your service partner can be found on the last page of the instructions for use.

OVERVIEW OF POSSIBLE FAULTS AND REMEDIES

Symptom / cause	Remedy	Who?
Not operating <ul style="list-style-type: none">› Power connection interrupted› Batteries dead› Door lock not closed correctly	Check the power connections Insert a new set of batteries Close door (door contact switch must be actuated)	Service Operator Operator
Paper jam	Cut off paper above drive shaft, remove remaining paper from drive unit and reload paper	Operator

CLEANING



General:

In order to maintain the hygienic conditions, the operating personnel must understand the cleaning section.



Caution!

Do not use a water jet or high-pressure cleaner for cleaning!
Clean the product only with a damp cloth.



Caution! Material damage!

Acidic detergents must not contain salt or hydrofluoric acids, as these can lead to discolouration of the surface or even rusting.

Detergents must be used in accordance with the manufacturer's instructions.

Stubborn stains require intensive cleaning, e.g. with a soft synthetic fleece. Then wash down with clear water.

Clean the product only with the detergents intended for this purpose and use only a small amount of water.



Warning!

Risk of injuries on sheet edges of the doors and carcass

MAINTENANCE

CLEANING FOR THE FIRST TIME



Once the product has been mounted or installed, it must be cleaned to remove all construction and/or mounting residues.

Use non-abrasive or acidic detergents for cleaning.

ONGOING CLEANING



Scour-free detergents must be used for cleaning.

Grease contamination and lipophilic pigment soiling are easily removed by means of

Multipurpose cleaners

Neutral cleaners

Alkali cleaners

To remove extremely stubborn grease contamination (congealed oils and fats) use solvent cleaners and scour-free emulsions.

INTERIOR CLEANING



Caution!

Prevent contact of moisture with the electrical components of the roll-fed paper towel dispenser.

This prevents property damage or injuries as the result of a short circuit.

DETERGENTS

Using incorrect detergents can damage the high-quality surfaces and cause them to lose their dirt-repellent effect.

The following table provides an overview of suitable detergents.

Agent	Comment
Mechanical detergent	
Bristle products	Brushes with natural or plastic bristles are well-suited
Textiles	Textile material made from natural and synthetic fibres for use as cleaning cloths (cleaning rags) and textile fabrics (machine and woven fabric, floor cloths, scouring cloth, fringed material, (non-woven fabrics). Cleaning fabrics made from microfibres are very well-suited for removing hand marks from stainless steel and chrome nickel steel surfaces.
Synthetic fleece	Without abrasive grains.
Other	Natural leather (chamois leather), artificial leather, synthetic fleece, sponges, absorbent cloths
Chemical detergents	
Multipurpose cleaners	Especially for lighter grease contamination
Neutral cleaners	For surfaces contaminated by oil and grease (fingerprints); also suitable as dishwashing liquid.
Alcohol cleaner	As multipurpose cleaner
Alkali cleaners	Especially for stubborn grease and oil (hardened oils)
Solvent cleaners	Depending on type, especially good at removing: Grease, oil, wax, tar, adhesives, lacquers, paints.
Scour-free emulsion cleaner	Especially for stubborn grease contamination, paints
Disinfectant cleaner	Action on pathogenic microorganisms – different, depending on disinfecting agent.
Acidic cleaners	Removes soiling such as lime scale, rust deposits, lipophilic pigment soiling, and lighter grease contamination.

TAKING OUT OF SERVICE

If the touch free paper roll dispenser is not used for an extended period of time (several weeks), it can simply be taken out of service:

Battery-powered products:

- › Remove batteries and dispose of them properly.

Mains-powered products:

- › Disconnect the product from the mains.
- › Remove the power cable completely and re-attach the cover plate over the terminal strip in the product.

Make sure that the product is not placed back in operation unintentionally. If necessary, attach an appropriate warning sign (e.g.: "Out of service, do not connect to mains")

DISPOSAL

- › Take the product out of service (see above)
- › Render the disused product unusable immediately to prevent subsequent accidents involving the product.
- › Dispose of the product in a proper, environmentally friendly manner (local regulations must be observed).
- › Dispose of used batteries in accordance with applicable laws and regulations

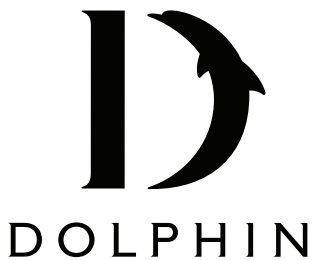

Dolphin Solutions Ltd

Southpoint, Compass Park, Bodiam,
Robertsbridge, TN32 5BS

Tel: +44 (0)1424 20 22 24

Fax: +44 (0)1424 205 200

info@dolphinsolutions.co.uk

www.dolphinsolutions.co.uk