

BC634F

DOLPHIN BEHIND MIRROR FOAM SOAP DISPENSER

INSTALLATION AND MAINTENANCE GUIDE



November 2021

INDEX

3	Technical Data
4	Pre-Installation Information
5	Pack Contents
6-7	Installation
8	Filling the Soap Tank
9	Settings Adjustment - Liquid Soap Dispenser
10	Batteries Replacement
11	Settings Adjustment - Foam Soap Dispenser
12	Maintenance
13	Spare Parts List
14-16	Troubleshooting

The information in this document reflects products at the date of printing. Dolphin Solutions Ltd reserves the right, subject to all applicable laws, at any time, at its sole discretion, and without notice, to discontinue or change the features, designs, materials and other specifications of its products, and to either permanently or temporarily withdraw any of the foregoing from the market. All information in this document is provided "as is" without warranty of any kind, either expressed or implied, including but not limited to any implied warranties of merchantability, fitness for a particular purpose, or non-infringement. Dolphin Solutions Ltd assumes no responsibility for errors or omissions in the information presented in this document. In no event shall Dolphin Solutions Ltd be liable for any special, incidental, indirect or consequential damages of any kind, or any damages whatsoever arising out of or in connection with the use or performance of this information. The tradenames, trademarks, logos and service marks presented in this document, including their design, are the property of Dolphin Solutions Ltd or other third parties and you are not permitted to use them without the prior written consent of Dolphin Solutions Ltd or such third party as may own them.

TECHNICAL DATA

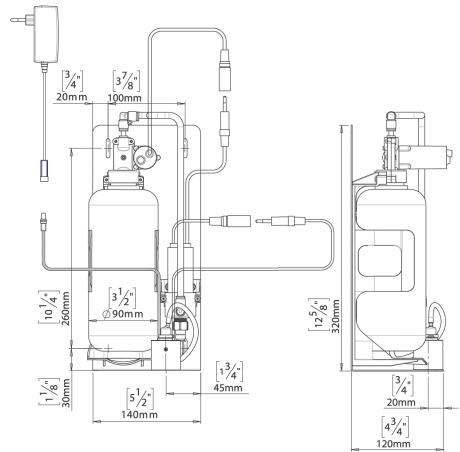
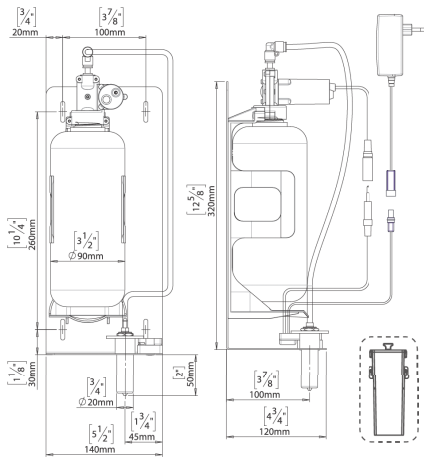

Capacity

1 Liter \ 33.8 oz.

Power Supply liquid soap dispenser

Battery box for 6xD batteries
12V transformer

Power Supply foam soap dispenser

12V transformer

Soap viscosity BTM Soap dispenser B/E

100-3800 cPs

Soap viscosity BTM Foam E

up to 100 cPs

Standard discharge BTM Soap dispenser B/E

1.4cc (customizable by optional remote control)

Standard discharge BTM Foam E

Varies according to viscosity and soap consistency

Sensor range

30-100 mm +/- 10 mm / 1.18-3.94"
(customizable by optional remote control)

PRE-INSTALLATION INFO

Check contents

Separate all parts from the packaging and check each part with the “Pack contents” section. Make sure all parts are accounted for before discarding any packaging material.

If any parts are missing, do not attempt to install your touch free soap dispenser until you obtain the missing parts.

Warnings

Do not install the system facing a mirror or any other electronic system operated by an infrared sensor. To prevent reflection problems, it is recommended to keep a minimum distance of 300 mm between the soap dispenser and any other objects.

Important: Pay attention that the dimensions of the mirror compartment fit the dimensions of the Behind Mirror Soap Dispenser mounting plate.

NOTE: Please ensure the cabinet base panel is not thicker than 26mm.

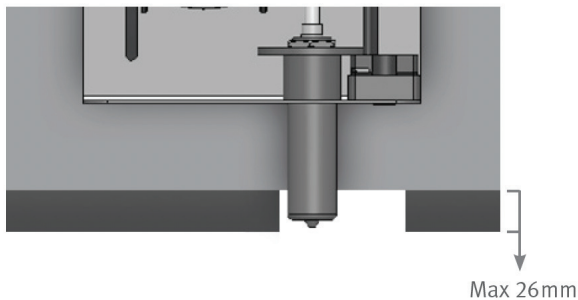

Dolphin soap dispensers, with proper care, will provide long term trouble free service. Quality liquid soap of recommended viscosity and pH levels are the main factors for smooth operation of your dispenser. If needed, use a viscometer to verify the viscosity of your soap to ensure maximum benefit. The recommended range for liquid soap viscosity is 100-3800 cPs and for foam - up to 100 cPs. Thicker liquid soap flows slower and inhibits the pump valve, causing strain and damage.

Dolphin soap dispensers are suitable for use with any generic liquid soap of the correct viscosity and pH. The pH level of all soap used in Dolphin soap dispensers should be between 6.5 to 8.5. Lower levels will cause corrosion to the metal dispenser and even the rubber and plastic components. Higher pH levels will cause swelling to rubber parts and degradation of plastic components over time.

PACK CONTENTS

Familiarize yourself with the part names and ensure that all the parts are included in your package.

BEHIND MIRROR SOAP DISPENSER



Product assembly containing: pump, bottle support, mounting plate with spout and soap tank



4 screws up to 5mm (not supplied)

BEHIND MIRROR FOAM SOAP DISPENSER



Product assembly containing: pump, air compressor; bottle support, mounting plate with spout and soap tank



4 screws up to 5mm (not supplied)



B Versions

Battery Box for 6xD
Alkaline batteries

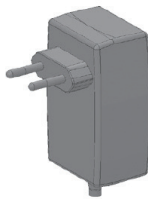

E Versions

12V Transformer

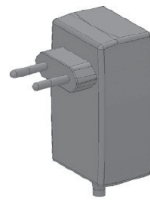

12V Transformer

INSTALLATION

Step 1 - Preparation for Installation

If needed cut a hole in the bottom of the mirror compartment for both soap dispenser sensor and spout.

Soap dispenser

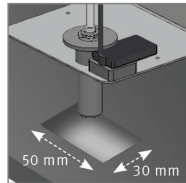

Foam Soap dispenser

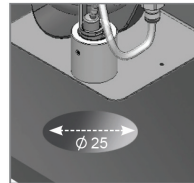

Step 2 - Installing the Soap Dispenser

1. Remove the protective sticker covering the sensor.
2. Place the soap dispenser assembly inside the mirror compartment with the spout sticking out of the hole.
3. Secure the plate to the wall with 4 screws (not supplied).

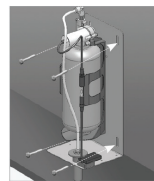
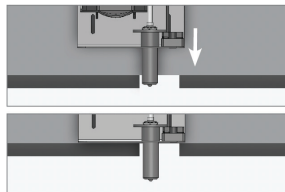
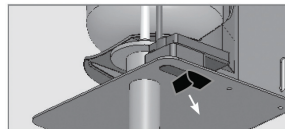

INSTALLATION

Step 3 - Connecting the Power Source

1. Make sure that the 4 contacts connector is connected properly so that the white o-ring is not visible.

Pay attention: If the 4 contacts connectors are not connected properly, the pump will work continuously.

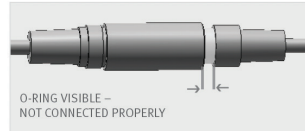

2. **A. For battery versions:**
Insert six (6) 'D'-size alkaline batteries into the battery box. Be sure to observe polarity configuration. Install the battery box next to the BTM unit. Connect the battery connector. Ensure adequate clearance to allow removal of the top cover and the battery carrier tray when a battery replacement is necessary.

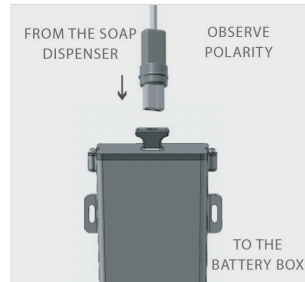

- B. For AC Adapter versions:**
Connect the transformer connector to the matching connector from the sensor and plug the transformer into the electricity socket.

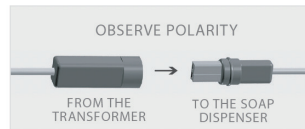

3. Wait about 10 seconds before placing your hands within the sensor range to avoid adjustment mode.

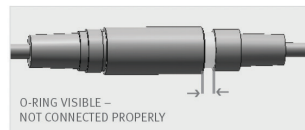

FILLING THE SOAP TANK

If your model is an MF model, please refer to the Multifeed installation guide.

1. Unscrew the soap tank from the pump assembly and pull it out from the bottle support.



2. Fill the bottle with liquid soap to the top line. Make sure the bottle is clean before filling it with soap.



3. Insert the bottle back into the bottle support.



4. Screw the soap tank back into the pump assembly. Make sure the tank is firmly secured into place.

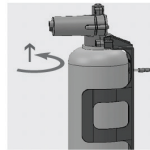

5. Press and hold the refill button located at the back of the pump assembly until soap is dispensed from the soap dispenser spout. Release the button once soap begins dispensing from the spout.

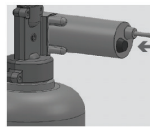

Alternately, use the FILL function on the remote control (if available). see page 14/15.



Note: When the soap in the soap tank reaches the bottom line, the tank needs to be refilled. To refill the soap tank please refer to steps 1-5.

SETTINGS ADJUSTMENT - LIQUID SOAP DISPENSER

If available, the soap dispenser remote control can adjust the dispenser's settings. To use the remote control hold it in front of the sensor at a distance of 10-15cm (4-6"). **Attention: The remote control will not operate out of the recommended range (too close or too far).**

The remote control can be used to adjust the following functions:

1 - Soap Quantity

The 1-4 drop keys allow the user to choose the desired soap quantity.

① 0.7 to 0.9cc ② 1.2 to 1.6 cc ③ 1.6 to 1.9 cc ④ 2.1 to 2.3 cc *

Indication: continuous blinking of the light in the sensor eye.

2 - ADJ

This function resets the sensor back to factory settings.

Indication: 2 blinks of the light in the sensor eye.

3 - Temporary Off Function

This function temporarily disables the dispenser. Use this function to perform maintenance in front of the sensor without activating the system (for example: cleaning). The soap dispenser will shut off for one minute after this button is pressed once.

To return to normal operation before the minute is over, press the On/Off button again.

Indication: OFF – 2 fast blinks, ON – 4 fast blinks

4 - Fill the Soap Tank

Once the soap tank has been filled \ refilled, press the FILL button. The pump will run for one minute, priming the piping with soap. Once soap begins dispensing from the spout, priming is complete. Press the FILL button again to stop the priming before the minute is over.

Indication: continuous solid light in the sensor eye.



BATTERY REPLACEMENT

Liquid soap dispenser battery model only

To replace the battery in battery models:

1. Carefully open the battery box, use a 2.5 mm Allen key
2. Remove the old batteries
3. Replace the used batteries with new D-size batteries
4. Close the box.

NOTE: Do not mix used batteries with new ones.

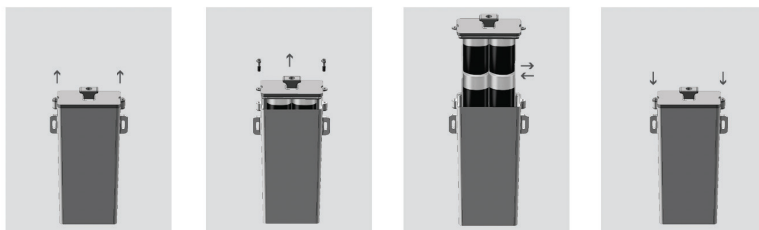

Important: Spent batteries should not be disposed of with normal household waste. Contact your local authority for information regarding waste disposal and recycling.



SETTINGS ADJUSTMENT - FOAM SOAP DISPENSER

If available, the foam dispenser remote control can adjust the dispenser's settings. To use the remote control hold it in front of the sensor at a distance of 10-15cm (4-6"). Attention: The remote control will not operate out of the recommended range (too close or too far).

The remote control can be used to adjust the following functions:

1 - Soap Quantity

Press the + sign on the SOAP button to increase the soap quantity by increasing the dispensing time. Press the - button to decrease it.

Indication: continuous blinking blue light in the sensor eye.

2 - Air Quantity

To improve soap consistency ("foamability") change the amount air to be mixed. Press the + sign on the AIR button to increase the air quantity and the - to decrease it.

Indication: 2 blinks of the blue light in the sensor eye.

3 - RES

This function resets the sensor back to its factory settings.

4 - Temporary Off Function

This function temporarily disables the dispenser. Use this function to perform maintenance in front of the sensor without activating the system (for example: cleaning).

The soap dispenser will shut off for one minute after this button is pressed once.

To return to normal operation before the minute is over, press the On/Off button again.

5 - Fill the Soap Tank

Once the soap tank has been filled \refilled, press the FILL button. The pump will run for one minute, priming the piping with soap. Once soap begins dispensing from the spout, priming is complete. Press the FILL button again to stop the priming before the minute is over.

Indication: continuous solid blue light in the sensor eye.

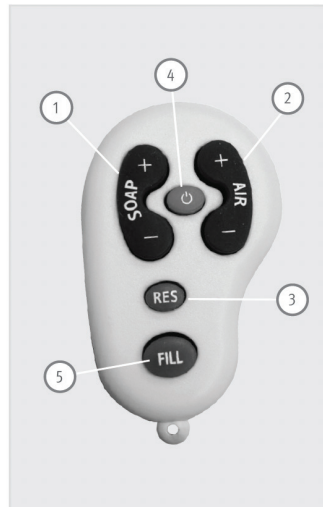

MAINTENANCE

Care and cleaning of chrome and special finishes

DO NOT use steel wool or cleansing agents containing alcohol, acid, abrasives, or the like. Use of any prohibited cleaning or maintenance products or substances could damage the surface of the soap dispenser. For surface cleaning use ONLY soap and water; then wipe dry with a clean cloth or towel. When cleaning bathroom tiles, the soap dispenser should be protected from any splattering of harsh cleansers.

Disassemble of the soap pipe from the pump

The soap pipe can be disconnected from the soap pump by a simple slide & pull action. The sliding ring of the quick connection fixation nipple on the pump should be pulled down. It releases the open end of the soap pipe which can then be easily pulled out.

Filter cleaning instructions (foam dispenser only)

This soap dispenser is provided with a foam filter. It is recommended to clean the filter every six (6) months.

If the soap supply has decreased, this may be caused by the clogged filter. The filter can be cleaned as follows:

1. Unscrew the quick connection fitting from the top of the foam compressor and pull out the filter housing.
2. Remove the filter from the housing and wash it under running water.
3. Reassemble the parts.

Clean the soap tank

Clean out the tank prior to refill by flushing warm water through the hoses and pump until clean water is released from the spout. TIP: Keeping a spare tank will enable this process to be completed in a speedy and hygienic manner with minimal downtime.

SPARE PARTS LIST

10-PACK SENSOR KIT – LIQUID	07220317
10-PACK SENSOR KIT – FOAM	08008003
SOAP DISPENSER PUMP (LIQUID/FOAM)	07222032
FOAM DISPENSER PUMP+COMPRESSOR KIT	07222044
SOAP DISPENSER SPOUT KIT (LIQUID ONLY)	07271023
6-PACK 1L SOAP TANK	07100035
6-PACK BOTTLE SUPPORT KIT	07100037
10-PACK FOAM DISPENSER FILTER	07212015
BATTERY BOX FOR 6XD BATTERIES (LIQUID ONLY)	06530041
12V TRANSFORMER (EU)	06522081
12V TRANSFORMER (UK)	06522086
12V TRANSFORMER (US)	06522080
12V TRANSFORMER (AU)	06522085
REMOTE CONTROL FOR SOAP DISPENSER (OPTIONAL)	07100008
REMOTE CONTROL FOR FOAM DISPENSER (OPTIONAL)	07100009
SOAP & WATER REMOTE CONTROL (OPTIONAL)	07100014

TROUBLESHOOTING

Indication	Investigation	Cause	Solution	Illustration
False activation: Soap/Foam dispensing	Continuous discharge from the nozzle	AUX connector not fully inserted	The connector should be inserted fully until white o-ring is not visible. Remove the o-ring if necessary	
	Random discharge from the nozzle	Reflection issue from basin or other object	Eliminate any cause of reflection and if necessary use appropriate remote control to shorten detection range.	
	Soap discharging from pump housing.	Damaged pump due to high viscosity or debris in pipes	Replace the Pump. Rinse warm water through the pipe and the body of the soap dispenser all the way to the nozzle.	
Soap/Foam not dispensing	Pump and/or compressor making sounds when sensor is activated	Soap tank is empty	Fill with soap with correct viscosity (100 - 3800 cPs for liquid soap and up to 100 cPs for foam) and prime pipes using the fill button on remote control.	
		Soap dispenser has not been primed	Prime the soap dispenser by pressing the fill button on the remote or by pressing the refill button located at the bottom of the pump, until soap exits the nozzle.	
		Damaged pump (discharge from housing)	Replace the Pump	
		Debris or dried soap in the pipe or tank	Run warm water through pipe, pump, and body all the way to the nozzle. Replace with soap of correct viscosity.	
		High viscosity soap (> 3800 cPs for liquid soap or > 100 cPs for foam)	NOTE: Using the soap dispenser with high viscosity soap may cause permanent damage to the pump and shorten the lifecycle.	
		Bent pipes	Unbend or straighten pipes.	

TROUBLESHOOTING

Indication	Investigation	Cause	Solution	Illustration	
Soap/Foam not dispensing	Pump is not making sound when the sensor is activated	Sensor is blinking when hand is placed in front	AUX connector not fully inserted	The connector should be inserted fully until the white o-ring is not visible. Remove the o-ring if necessary	
		Refill button on pump does not activate the pump.	Replace the Pump. Rinse warm water through the pipe and the body of the soap dispenser all the way to the nozzle.		
		Damaged pump (discharge from housing).			
		Debris or dried soap in the tank or tubing	Run warm water through pipe, pump, and body all the way to the nozzle. Replace with soap of correct viscosity. NOTE: Using the soap dispenser with high viscosity soap may cause permanent damage to the pump and shorten the lifecycle.		
	Sensor is not blinking when hand is placed in front	Refill button on pump does not activate the pump.	Transformer: Check operation with functioning transformer. Where necessary replace with appropriate transformer. For part numbers see spare parts list. Battery: Check operation with functioning battery pack. Where necessary, replace batteries or replace the battery pack: Battery pack (without batteries)		
		Reflection issue from basin or other object	Eliminate any cause of reflection and use appropriate remote control to shorten detection range.		
		Damaged sensor	If the above two solutions have not resolved this issue replace with appropriate sensor. For part numbers see spare parts list.		

TROUBLESHOOTING

Indication	Cause	Solution	Illustration
Foam not dispensing	Liquid rather than foam is being dispensed out of the nozzle	1. Increase the air to soap ratio.	
		2. Verify that the filter is clean.	
		3. Replace compressor (supplied with pump). For part numbers see spare parts list.	
Foam is dispensing	Foam dosage is too large	Use remote to decrease soap volume by pressing the "- Soap" key.	
	Foam dosage is too small	Use remote to increase soap volume by pressing the "+ Soap" key.	
	Foam is too dense	Use remote to decrease the amount of air in the foam by pressing the "- Air" Key.	
	Foam is too liquefied	Use remote to increase the amount of air in the foam by pressing the "+ Air" key.	

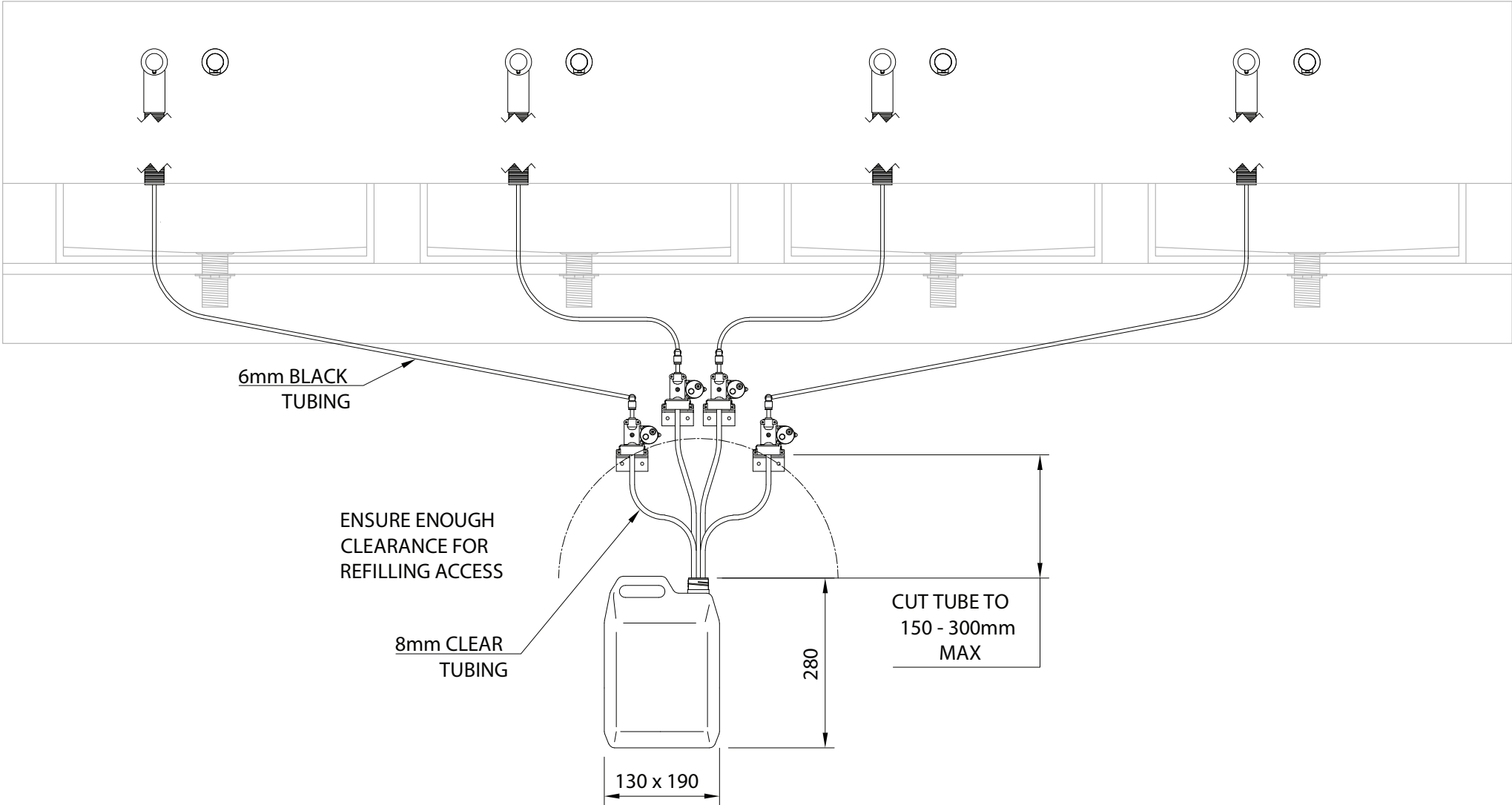



Dolphin Solutions Ltd

Southpoint, Compass Park, Bodiam,
Robertsbridge, TN32 5BS

Tel: +44 (0)1424 20 22 24

Fax: +44 (0)1424 205 200

info@dolphinsolutions.co.uk

www.dolphinsolutions.co.uk