



DSI02

DOLPHIN WALL PLATE MOUNTED INFORM (SMART) TAP

INSTALLATION AND MAINTENANCE GUIDE

PRODUCT CODES

- DSI02.130 > 130mm Projection
- DSI02.180 > 180mm Projection
- DSI02.230 > 230mm Projection
- DSI02.280 > 280mm Projection
- DSI02.330 > 330mm Projection

DS102

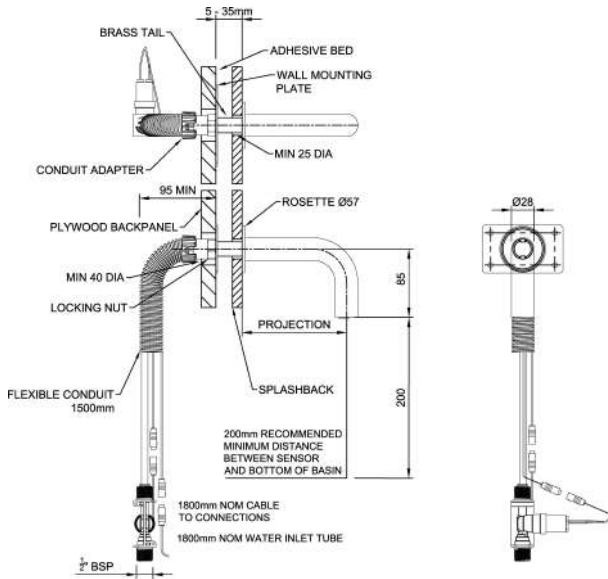

TECHNICAL DATA

- › Dolphin Wall Plate Mounted InForm (SMART) Tap
- › Manufactured from high-quality, highly durable 1.4401 (316) Marine grade stainless steel.
- › Self-Monitoring Analysis and Recording Technology (SMART) allows the Facilities Manager to connect point to point via the Dolphin SMART App when used with the optional Bluetooth Adaptor (Sold separately -Order product code 25148)
- › Infra-Red Touch Free Tap for ultimate hygiene prevents cross contamination Sensor mounted in end of spout
- › Designed to be front mounted for when rear access installation is not possible
- › Flow rate - 3.78 litres/minute with the standard fitted flow regulator (contained within Neoperl TT cache aertor) at any pressure between 0.5 and 6 bar*
- › Other flow rates including 1.89 litres/minute available to special order please enquire*
- › Water Supply: Single inlet cold or pre-mixed a TMV2 or TMV3 thermostatic mixing valve is recommended for premixed applications
- › Maximum operating water temperature - 60°C
- › Power Supply: **
- › Nominal Current: Less than 1mA (Less than 25mA with Bluetooth)
- › Nominal Power: Less than 1W
- › Security Time can be adjusted via the App
Default 20 Seconds (60 Seconds max)
- › IP68 Connector

* See page 4 for flow rates and other options

** See page 3 for power supply options

PRODUCT CODES

DS102.130	› 130mm Projection
DS102.180	› 180mm Projection
DS102.230	› 230mm Projection
DS102.280	› 280mm Projection
DS102.330	› 330mm Projection

Coding Explained

Style

DS102 90° Bent Spout - Wall Mounted
DS10X.XXX.X

Projection

130/180/230/280/330mm
DS10X.XXX.X

Finish

1 Brushed Satin
2 Mirror Polished
3 PVD Brushed
4 PVD Mirror
5 Powder Coated
DS10X.XXX.0

Colour

Suffix to end of code

(Number allocated by Dolphin Solutions)

Example Coding DS102.130.1

90° Bent Spout
130mm Projection
Brushed Satin Finish

Options

Bluetooth 
PVD
Powder Coating

PACK CONTENTS

- 1 Solenoid Adapter
- 2 6v DC Solenoid
- 3 1/2 Cartridge
- 4 8mm Tube
- 5 Tail
- 6 M20x1.5 P 1/2 Nut
- 7 Backplate
- 8 Rosette
- 9 Body
- 10 M5x5 Grub Screw
- 11 M5x6 Grub Screw
- 12 Aerator
- 13 Aerator Housing
- 14 Sensor Assembly
- 15 Conduit Adapter
- 16 Conduit

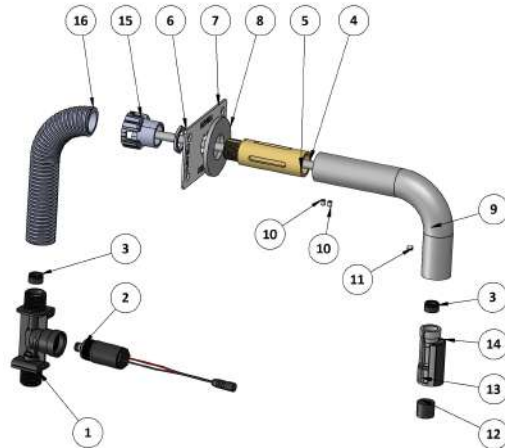

Options



✓ ? Order 25148 separately

Standard

Power Supply Options:**
 25147 UK Mains Adaptor
 25428 EURO Mains Adaptor
 25240 Hardwire Transformer
 25241 Battery Pack



Bar
0.5 min
6.0 max

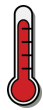

°C
60 ✓



L/min
3.78 max @ 2 bar

PRE INSTALLATION

› Please check that all the components in the list above are present and that they are in good condition before installation. If any components are missing contact Dolphin Solutions.

⚠ WARNING

› Highly reflective surfaces directly beneath the sensor of this product, in particular polished finish basin wastes/strainers, will cause false activation of the infrared sensors and can result in malfunction. We recommend Satin or Matt finish products which can be found on our website.

› Sitting water may also cause the tap to activate

› All Plumbing and Electrical installation must be carried out by a qualified person and in accordance with applicable codes and regulations.

› Do not kink the water supply hose.

INSTALLATION

1 Flush pipes thoroughly before and after installation

2

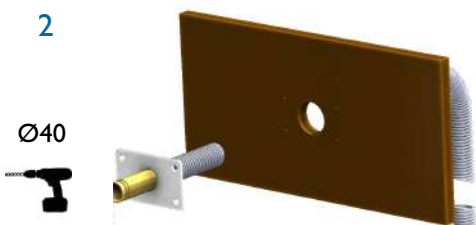

3



Fix the wall Tail/Mounting Plate assembly with 4 screws supplied. **IMPORTANT:** Slot to be on underside of tail. Ensure wall plate is level as this dictates tap angle and rotation. Protect Brass Tail with low tack tape / other suitable method

4

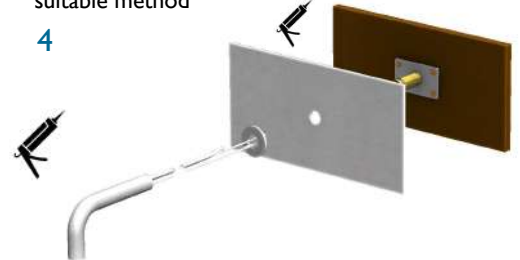

Fit Splashback with adhesive (or other fixing method as required) leaving mounting assembly protruding

Insert in order - plugged cables and then pipe from the tap into mounting assy and feed through. **DO NOT** Remove connectors from cable or pipe ends until after they have passed through the conduit.

5

Remove Protective tape from tail. Fit Rosette (if required) over mounting assembly. Slide tap body onto mounting assy and secure with grub screw from beneath



6



1/2" BSP

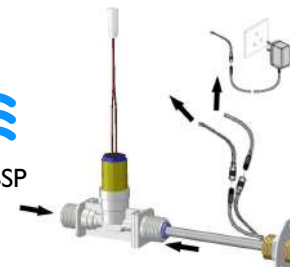

7

› Switch on power supply

› The sensor is self adjusting.*

*Further adjustments can be made by purchasing the Bluetooth Adaptor and downloading the App

8



Open hot and cold water supply and check that connections are watertight.

MAINTENANCE

DO NOT use steel wool or cleansing agents containing alcohol, acid, abrasives or the like. Use of any prohibited cleaning or maintenance products or substances could damage the surface of the tap. For surface cleaning of tap use **ONLY** soap and water then wipe dry with a clean soft cloth. Protect taps from splattering of harsh cleansers when cleaning surroundings.

OPTIONS

Flow Rate Curve

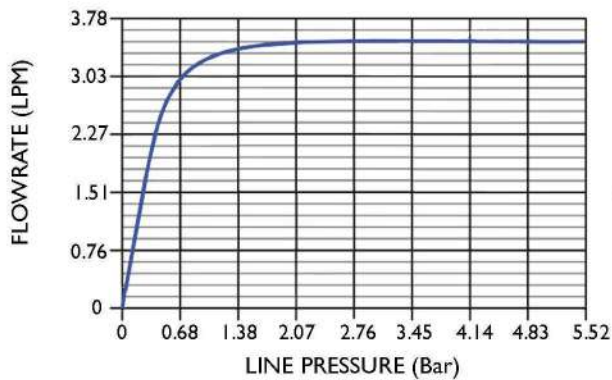

— PCA

PCA® Perlator®
Faucet Aerator - 3.78 lpm max
 Pressure Compensating Tom Thumb® Size

Flow Rate Curve

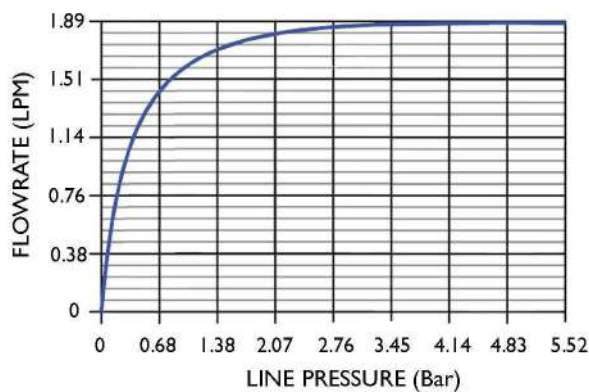

— PCA®



PCA® Perlator®
Laminar Stream - 1.89 lpm max
 Pressure Compensating Tom Thumb® Size

POWER SUPPLY OPTIONS

UK MAINS ADPATOR PRODUCT CODE 25147
 (Other Adaptor pin and power supply configurations available upon request):

- > Input voltage: 100 240V AC +/- 10%, 50 - 60 Hz
- > Output voltage: 6.75V DC + 0.15V/ -0.35 V
- > Secondary current: 0 - 350 mA DC
- > Buffer capacitors: The adaptor secondary contains 3 buffer capacitors (necessary to close the solenoid valve in case of power outage):
 - 2 x 2200 µF,
 - 1 x 100µF
- Certifications: EN 60335-1, EN 60950-1
- > 1m Cable

HARDWIRE TRANSFORMER PRODUCT CODE 25240

- > Input voltage: 100 240V ± 10% 50-60 Hz ± 3 Hz
- > Output voltage: 6.6V DC ± 5%
- > Secondary current: 200 mA DC
- > Buffer capacitors: one buffer capacitor 4700 µF (necessary to close the solenoid valve in case of power outage)
- Certifications: EN 60335-1, EN 61558-2
- > 1m Cable (Transformer to Tap), 2m Cable (Transformer to Mains)

BATTERY PACK PRODUCT CODE 25241

- > Requires a 6V lithium battery (CR-P2, approx. 1.500mAh) which has a lifetime of 200.000 switching cycles or 3-5 years depending on user frequency.
- > 100mm Cable (Approx)
- > **Important note** - the battery unit can't be used in combination with the Bluetooth adaptor.

The battery unit contains the CR-P2 battery as delivery content. The housing enables a fixation on wall by using the mounting clips (part of the housing but screws are not included) or the rear affixed Velcro tape

BLUETOOTH ADAPTOR PRODUCT CODE 25148



The **current version** of the app required for using the system **must** be installed on the control unit in advance. The App is available for free in the iTunes Store (requires an Apple account) and the Google Play store (requires a Google account).

For operation under adverse environments, in buildings / rooms with reinforced concrete walls, steel and iron frame, or near of obstructions (eg furniture) of metal, the Bluetooth reception can be disturbed and interrupted.

Bluetooth®:

Power consumption:	Less than 25mA
Output:	Bluetooth® - Class 2
Bluetooth® - version:	4.0
Bluetooth® - Transmission distance:	about 10m (depending on the environments)
Automatic safety shut-off:(10/20/60 seconds - adjustable)	20 s
Run-on time (0 - 10 s adjustable):	1 s
Detection Range - Levels 1 to 10 (10 = 120mm approx)	10