

DECLARATION OF PERFORMANCE

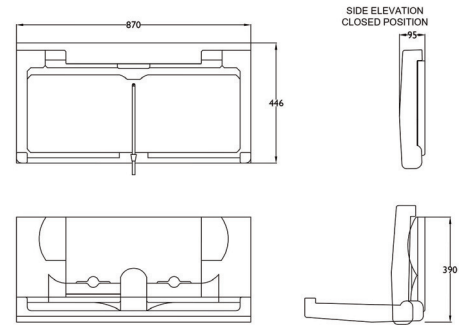

BC100EH

DOLPHIN HORIZONTAL NAPPY CHANGING UNIT

- > Designed for infants only. Age up to 3.5 years and weight less than 22.7kg (50lb)
- > Easy to clean, high density polyethylene which inhibits bacterial growth
- > Safety belt with cam buckle is adjustable with one hand
- > Pneumatic gas shock mechanism to ensure smooth and safe opening and closing
- > Includes safety labels, easy to install, step-by-step instructions plus all mounting hardware for timber stud wall construction
- > The most preferred changing position
- > Clean design fits virtually all decors and is excellent for cost conscious customers
- > Includes a integrated liner dispenser, mounting hardware for timber stud wall construction, safety straps and buckle
- > EZ Mount™ Backer plate is an optional extra for this unit
- > The unit meets all of the standards of EN 12221:2008+A1:2013 (minus clause 4.1)
- > 5 year Warranty: This product is warranted against manufacturing defects for a period of 5 years.

PRODUCT CODES

> EZ Backing plate

BC100-BPEH

This is to confirm that the BC100EH is suitable for purpose as a horizontal nappy changing unit and conforms with regulations



Chris Beattie
Dolphin Solutions Ltd