

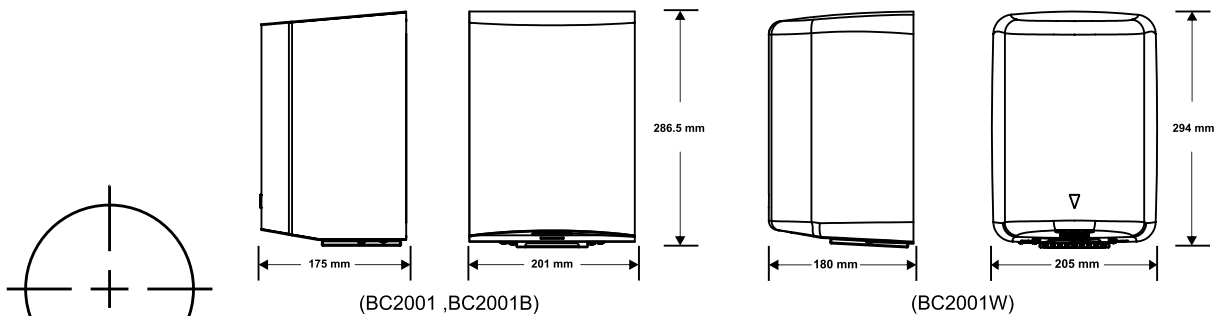

DRYER MOUNTING TEMPLATE

Fix this card on the wall.

Drill 4 holes
(A. B. C. D. 8 mm diameter:35 mm depth.)



'Unit should be mounted to give no less than 300mm clearance from the bottom of the unit to the nearest surface below'

CONNECT DESCRIPTION

1. Secure the base plate on the wall provided.
2. The conduit in place by suitable 1/2 inch trade conduit fitting.
3. Connections:
 - A. Connect the live wire (colored black, brown or dark) to the terminal block marked "L".
 - B. Connect the neutral wire (colored white, blue or light) to the terminal block marked "N".
 - C. Connect the ground wire (colored green or green and yellow) to the terminal block marked "⊕".

232mm

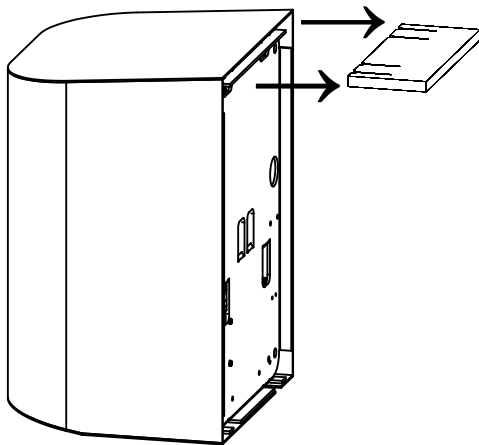

Remove cardboard insert before installation

Important Information

This Product falls within the scope of the Waste Electrical & Electronic Equipment Directive 2012/19/EU. (WEEE)



NOTE:

This Product should not be disposed of with household waste. Please recycle where facilities exist. Check with your local authority for recycling advice.



THIS UNIT MUST BE FITTED AND SERVICED BY SUITABLY QUALIFIED PERSONNEL